

**Foodservice Equipment • Material Handling, Healthcare & Cleanroom Equipment • Retail Display**

## RedHots® Hot Plates



#LCW-120-2-W



#LCW-120-2



#LW-120-1



#CW-120-2

Item #: \_\_\_\_\_  
 Model #: \_\_\_\_\_  
 Project #: \_\_\_\_\_  
 SIS #: \_\_\_\_\_

Optional Accessories	Model #	Qty.
Set of 2½" (64mm) legs	309197	



- Exterior body is constructed of highly polished type 430 stainless steel for lasting beauty and durability.
- Models offered are 5¾" or 12½" (146 or 318mm) high, single or double elements.
- Infinite controls provide accurate heat setting and are equipped with an Off-on signal light.
- Swing-up elements each have removable drip pans for easy cleaning.
- Models offered are field-wired or come with cord.
- All units are 60 cycle single phase.

Spec sheets available for viewing, printing or downloading from our online literature library at [www.eaglegrp.com](http://www.eaglegrp.com)

For custom configuration or fabrication needs, contact our **SpecFAB Division**.  
 Phone: (302) 653-3000. FAX: (302) 653-3091.  
 E-mail: [specfab@eaglegrp.com](mailto:specfab@eaglegrp.com)

# RedHots® Hot Plates

## Design and Construction Features

- Swing-up elements with removable drip pans for easy cleaning.
- All type 430 stainless steel body.
- Infinite controls provide accurate heat setting.
- Provided with off-on indicator light.
- 8" (203mm) diameter heating elements for maximum heat transfer.
- Supplied with cord and 15-amp NEMA 5-15 120-volt plug. Models C-208-2 and C-240-2 require field wiring.

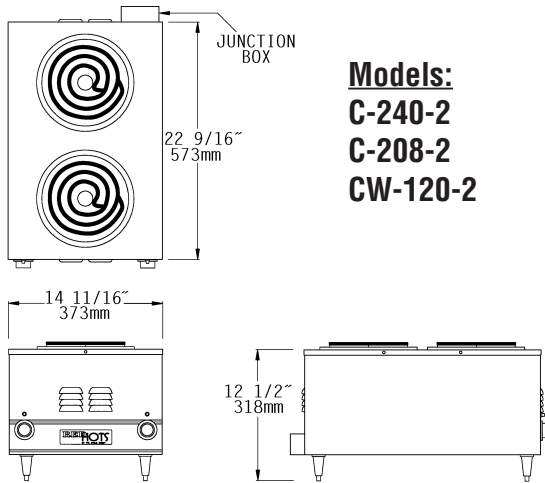

**Models:**  
C-240-2  
C-208-2  
CW-120-2

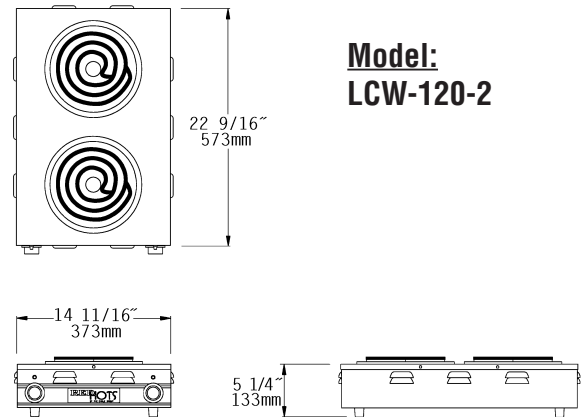

**Model:**  
LCW-120-2

weight		electrical data				model #
lbs.	kg	volts	amps	watts (front burner)	watts (back burner)	
30	13.6	120V	13.6A	1125W	525W	CW-120-2
30	13.6	208V	15.2A	1575W	1575W	C-208-2
30	13.6	240V	17.5A	2100W	2100W	C-240-2

weight		electrical data				model #
lbs.	kg	volts	amps	watts (front burner)	watts (back burner)	
22	10.0	120V	13.6A	1100W	525W	LCW-120-2

2 1/2" (64mm) legs are standard on these models.

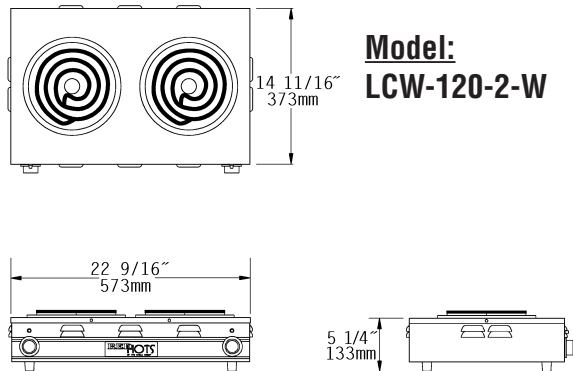

**Model:**  
LCW-120-2-W

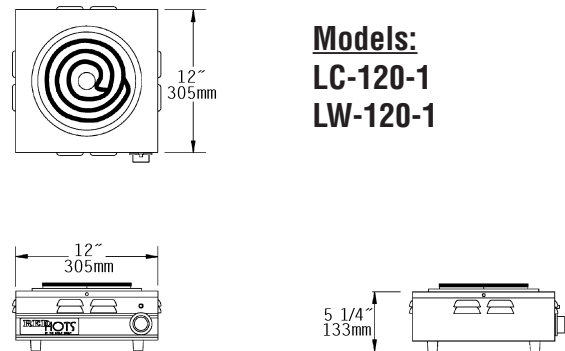

**Models:**  
LC-120-1  
LW-120-1

weight		electrical data				model #
lbs.	kg	volts	amps	watts (left burner)	watts (right burner)	
22	10.0	120V	13.6A	1100W	525W	LCW-120-2-W

weight		electrical data				model #
lbs.	kg	volts	amps	watts		
12	5.4	120V	9.2A	1100W		LC-120-1
12	5.4	120V	4.4A	525W		LW-120-1

New York M.E.A. No. 378-84-E